

DJ

## INDUSTRIAL SPRAY NOZZLES - FLAT SPRAY

### SPRAY CHARACTERISTICS

- *Wide flat spray of liquid with even distribution except for the edges which have heavier deposit.*
- *Wide spray angles, on water, for low pressure.*
- *Useful with steam or air for blow-off application.*

### CONSTRUCTION AND MATERIALS

- *Straight through slot shaped orifice.*
- *One piece Male BSPT thread only.*
- *Hexagon body with wrench flats avoid distortion when tightening.*
- *Larger thread sizes are available on request.*
- *Brass and Stainless Steel are standard.*
- *Other materials available to special order.*

### ORDER EXAMPLE

*1/4" DJ 24 Brass.*

Maximum Recommended Pressure:

70 Bar.G. (Metal) 7 Bar.G. (Plastic)}



## CAPACITY CHARTS

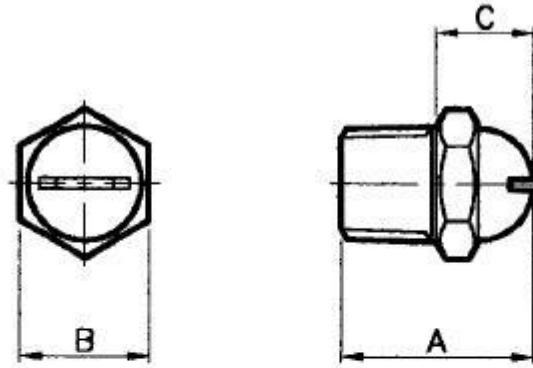

### DIMENSIONS AND WEIGHTS

Thread Size	Dimensions (mm)			Weight (g)
	A	B Hex	C	
1/4	30,0	15,3	10,3	28
3/8	35,0	18,0	14,3	45

### WATER CAPACITY CHART

NOZZLE NUMBER MALE	APPROX SLOT WIDTH (mm)	BSPT THREAD SIZE		FLOW RATE IN LITRE/MIN AT Bar.G.							SPRAY ANGLES (°) AT Bar.G.		
		1/4	3/8	0,7	1	2	3	4	5	7	1	3	7
				DJ 10	0,25		1,1	1,4	1,7	2,1	2,4	2,7	3,2
DJ 14	0,35		1,2	1,5	2,0	2,3	2,6	3,0	3,5	85	100	105	
DJ 18	0,45		1,6	1,9	2,6	3,0	3,4	3,8	4,5	75	90	95	
DJ 24	0,60		2,1	2,5	3,5	4,0	4,6	5,1	6,0	90	90	100	
DJ 31	0,80		2,7	3,2	4,5	5,2	5,9	6,6	7,8	80	90	100	
DJ 40	1,00		3,7	4,3	6,0	8,8	10,1	11,3	13,3	90	95	110	
DJ 46	1,20		4,2	5,0	6,9	10,1	11,6	13,0	15,3	95	110	115	
DJ 93	2,40		12,4	14,9	20	26	31	35	41	80	85	90	

### AIR CAPACITY CHART

NOZZLE NUMBER MALE	APPROX SLOT WIDTH (mm)	BSPT THREAD SIZE		FLOW RATE IN LITRE/MIN AT Bar.G.							SPRAY ANGLES (°) AT Bar.G.		
		1/4	3/8	0,7	1	2	3	4	5	7	1	3	7
				DJ 10	0,25		35	46	56	69	78	88	105
DJ 14	0,35		39	49	65	75	85	98	114	80	95	100	
DJ 18	0,45		52	62	85	98	111	124	147	70	85	90	
DJ 24	0,60		69	82	114	131	150	167	196	75	85	95	
DJ 31	0,80		88	105	147	170	193	216	255	75	85	100	
DJ 40	1,00		121	141	196	288	330	370	435	85	90	105	
DJ 46	1,20		137	164	226	330	379	425	500	90	105	110	
DJM 93	2,40		405	487	654	850	101	1145	1341	75	80	85	

# STEAM CAPACITY CHART

NOZZLE NUMBER MALE	APPROX SLOT WIDTH (mm)	BSPT THREAD SIZE		FLOW RATE IN Kg/HOUR AT Bar.G.							SPRAY ANGLES (°) AT Bar.G.		
		1/4	3/8	0,7	1	2	3	4	5	7	1	3	7
DJ 10	0,25			1,3	1,7	2,0	2,5	2,9	3,2	3,8	80	95	100
DJ 14	0,35			1,4	1,8	2,4	2,8	3,1	3,6	4,2	80	95	100
DJ 18	0,45			1,9	2,3	3,1	3,6	4,1	4,6	5,4	70	85	90
DJ 24	0,60			2,5	3,0	4,2	4,8	5,5	6,1	7,2	75	85	95
DJ 31	0,80			3,2	3,8	5,4	6,2	7,1	7,9	9,3	75	85	100
DJ 40	1,00			4,4	5,2	7,2	10,5	12,1	13,5	15,9	85	90	115
DJ 46	1,20			5,0	6,0	8,3	12,1	13,9	15,6	18,3	90	105	110
DJ 93	2,40			14,9	17,8	24,0	31,0	37,0	42,0	49,0	75	80	85